

# CITY OF PERTH LIGHT IT UP COMMISSION

DESIGN DOCUMENTATION –  
CITY OF PERTH LIGHT IT UP COMMISSION

OCTOBER 2021

## **PAMELA GAUNT**

12 CANTLE STREET, PERTH 6000 WA

EMAIL: PMGAUNT1@GMAIL.COM

MOB: 0421 657 477

ABN: 48 200 175 022

BSB: 086 061

ACCOUNT NO: 124436762

NAB 100 ST. GEORGES TCE.

NAVA MEMBERSHIP NO: 146281 PUBLIC LIABILITY INSURANCE \$20,000,000



# CONCEPT INTRODUCTION

## City of Perth Light It Up

The site was chosen as the preferred location for several reasons:

- o The concept of the illuminated floating forms is conceived as a disruption in response to the strong architectural geometry of the site. This is further discussed in the concept proposal below.
- o The size of the laneway allows the proposed artwork to fit within the budget, although there is some flexibility with its form (i.e. it could be expanded or more concentrated without increasing the LED elements for other applications, but may feel somewhat diluted).
- o The walls are reasonably free from clutter, such as pipes and air conditioners, and thus, would be easier to accommodate a catenary system than some of the other sites.
- o Because of the narrow characteristic of the lane, a red glow would be visible from further down Irwin Street without the artwork revealing itself, enticing the public to investigate the origin of the glow.
- o Its visibility from the Westin Hotel tower and surrounding restaurants would encourage patrons to engage with the artwork at ground level.

The artwork is most suited to the location for conceptual and contextual reasons and to maximise its potential within a constrained budget.

Background and Concept Introduction:

### **Unwoven**

The 19th C architect and academic Gottfried Semper,\* considered structural textiles as the driving force behind the birth of architectural form. Its tectonic precursor so to speak. If we examine the structural nature of woven textile cloth, it embodies a strong geometry with the vertical warp (fibre) being the stable element and a horizontal weft. But contrastingly, and unlike architecture, it offers a kind of 'floppy geometry' one that can be moulded and changed according to natural elements and its own materiality.

**Unwoven** responds to, and draws inspiration from, the context of the specific site. The artistic intention for the Light It Up proposal stems from the desire to disrupt the strong Formalism evident in the architecture of the buildings surrounding the north laneway of Irwin Street. The narrow space appears dwarfed by the surrounding horizontal/vertical rigidity, particularly the District Court. Also in consideration, is the Westin Hotel tower (opposite) that maintains a strong presence from Irwin Street. Whilst this building is geometrically omnipresent, its watery, mirrored glass façade would seem to visually and conceptually fit somewhere between the artwork proposed and the rigid geometry mentioned above.

Whilst intended as a counterpoint to what exists, **Unwoven** seeks to simultaneously operate in harmony with the surrounding geometry, activating the space by playfully teasing its edges and inviting the public to experience its rhythmic length.

The initial idea for this proposal was conceived as an undulating, illuminated, loosely woven form materializing from a floating LED structure (or series of structures) comprised of coloured Flextube Arching LEDs, that mimic a piece (or series of) woven textiles, floating down a laneway. The LEDs would float and flow down the laneway; its catenary hanging system hardly visible nocturnally. The concept offered a perfect dual disruption to the architecture and simultaneous connection to tectonic architectural history. This initial concept proposal was abandoned due to budget constraints.

The second iteration of the idea evolved to free the weft elements from the structural warp of the woven configuration. Thus, the weft becomes free form and flows down the laneway to play with the built structure. In removing the stable element, the weft elements create visual movement through the laneway, unrestrained by the previous grid. Whilst **Unwoven** will be dynamic in the space, it will also offer quiet visual contemplation – a contrast to some of the more heroic illuminated works in the City of Perth.

The piece will be visible from the Westin Hotel tower and other restaurants facing the laneway. The eb and flow of patrons from adjacent buildings will be attracted to the site and drawn to investigate the work at a more intimate ground level. It is anticipated the work will invite the public to walk the distance of the artwork to experience the visual changes from different angles as it negotiates the space.

The significance of **Unwoven** is: its innovative approach to illumination; its unheroic yet engaging shifting presence and sensorial appeal; and its contextual relevance to the site. These qualities are part of the artist's raison d'être

# LOCATION PLAN

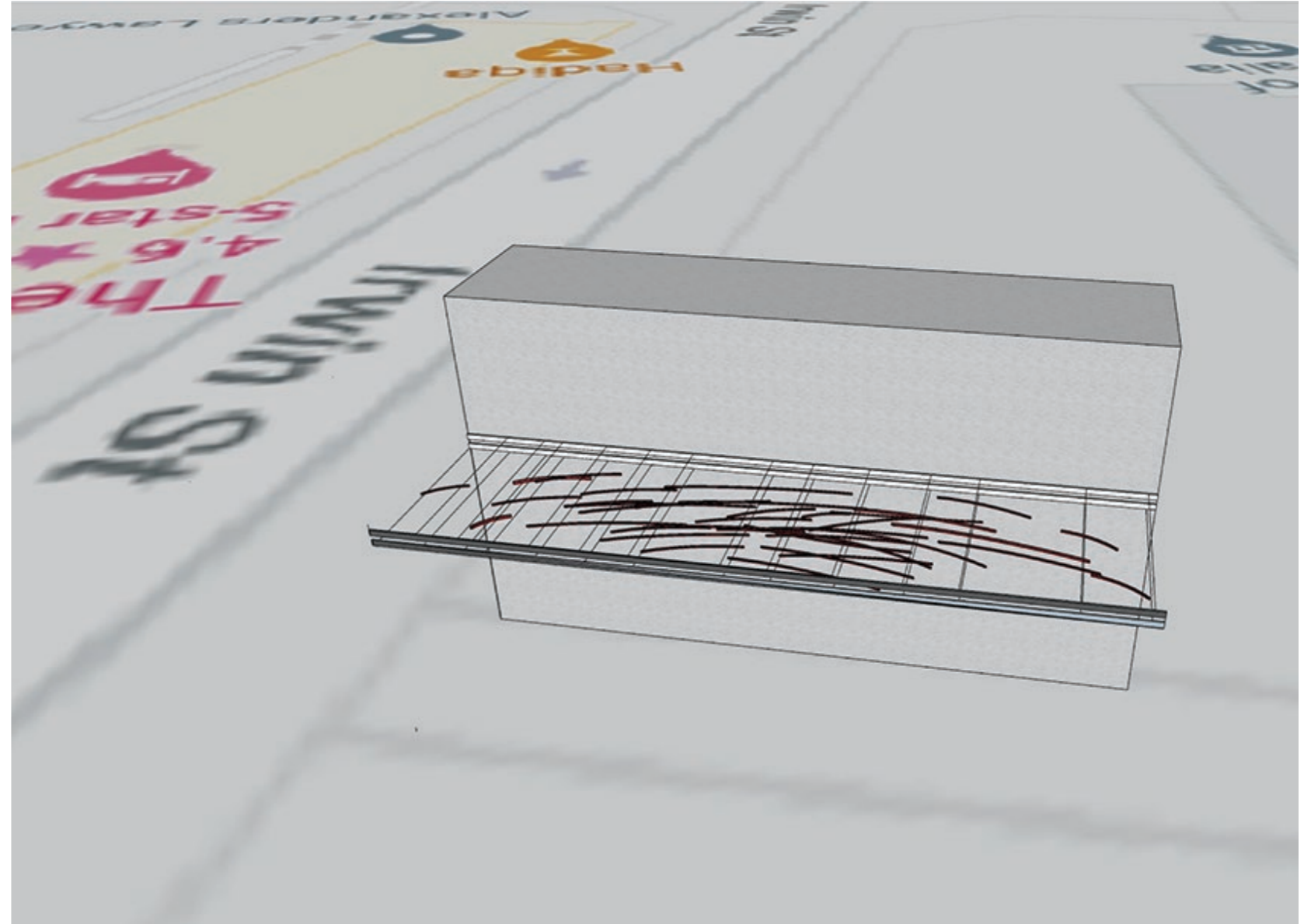
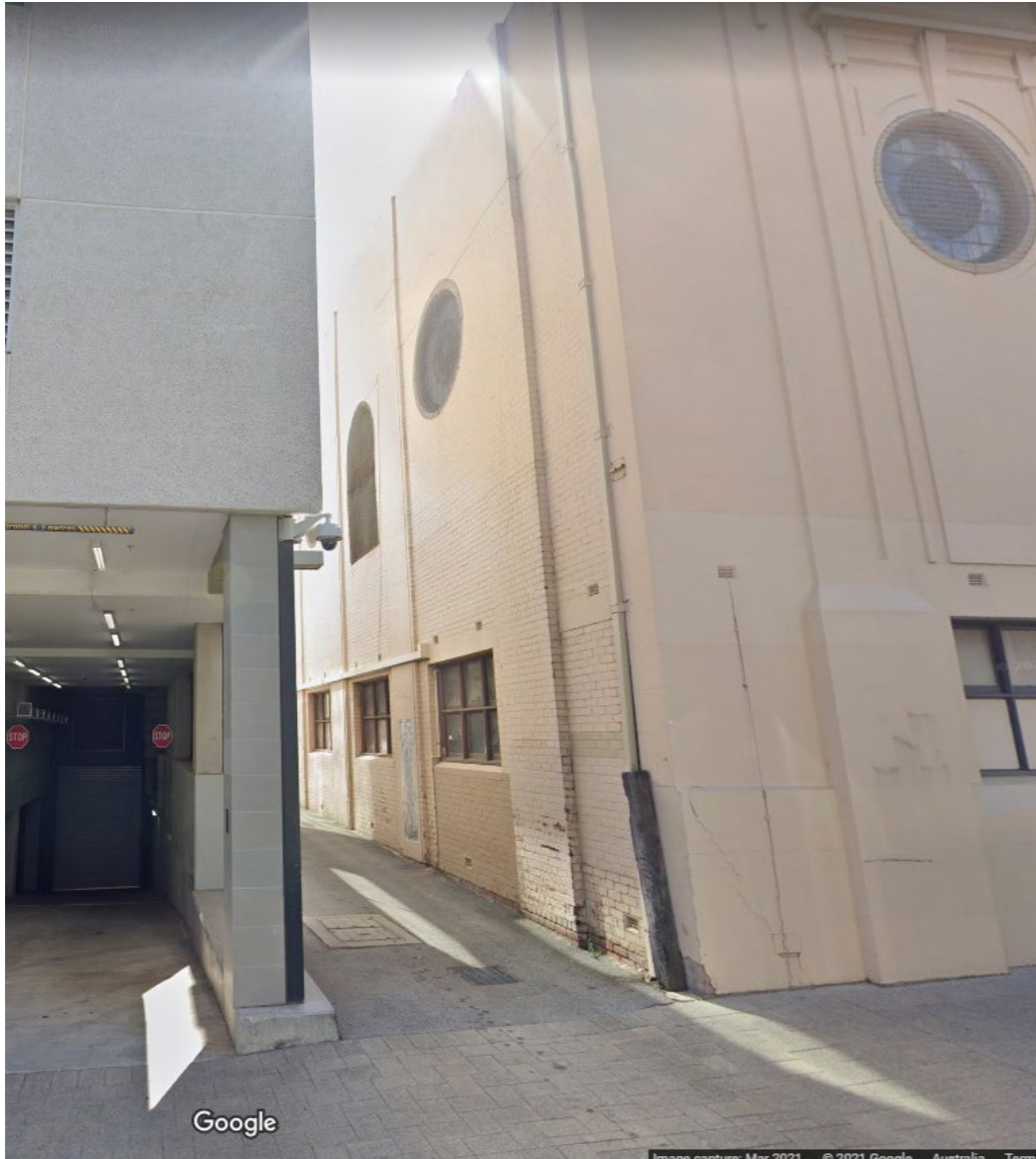

Location image showing extent of proposed artwork flowing through laneway off Irwin Street.



# ARTWORK CONCEPT

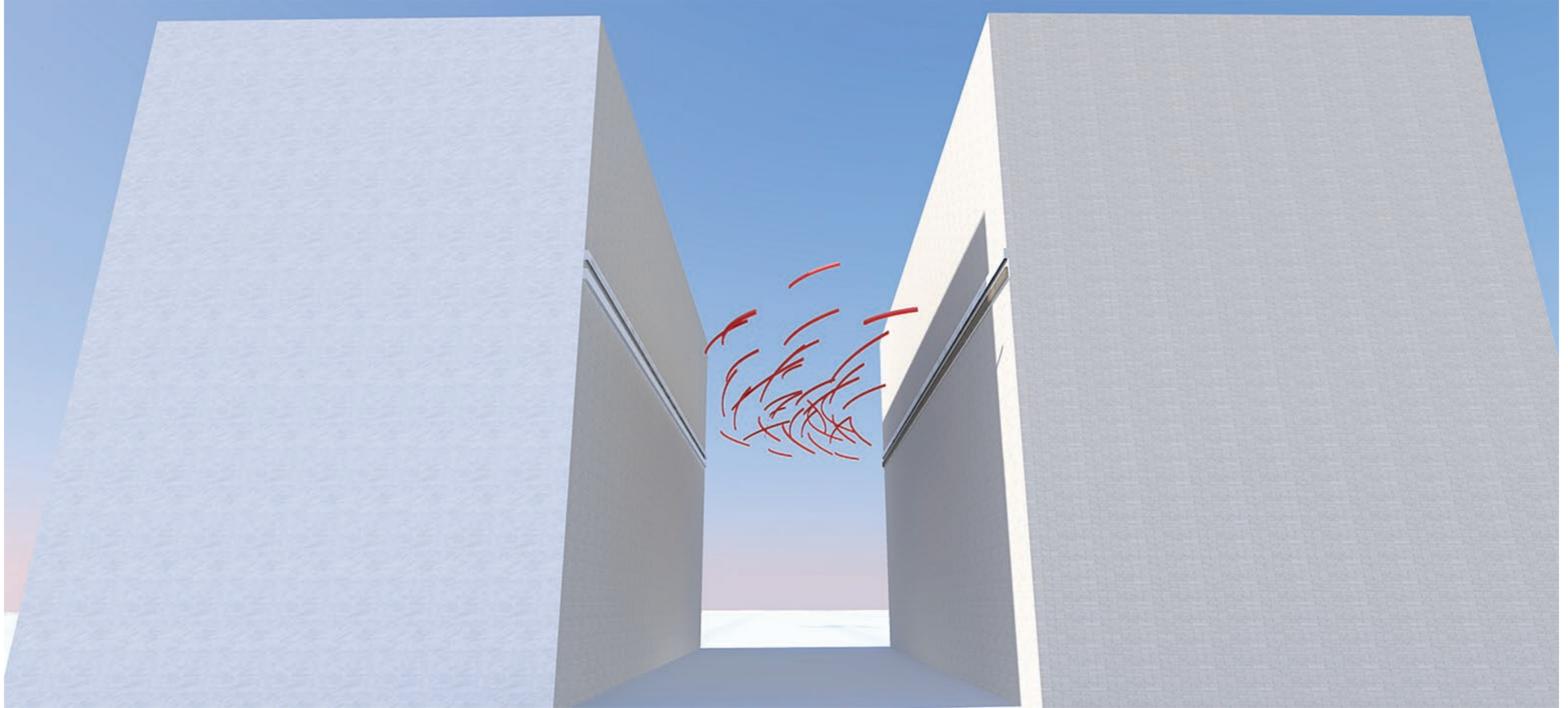

Indicative view of proposed illuminated artwork from Irwin Street.  
The artwork will comply with minimum height constraints to allow trucks to pass through (4400mm above ground).

# ARTWORK CONCEPT

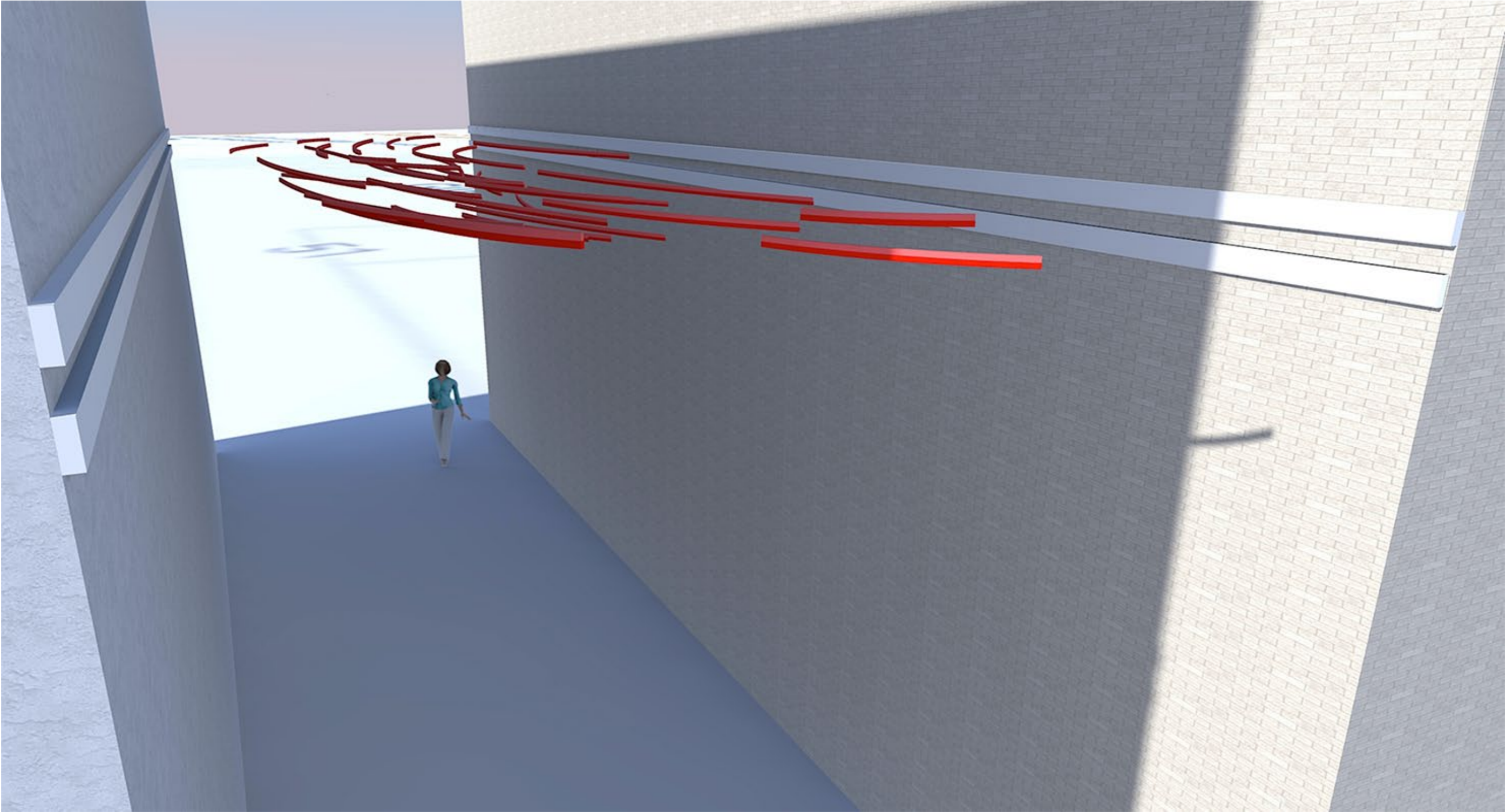

Indicative view of proposed artwork from restaurants opposite, in Irwin Street.



# ARTWORK CONCEPT

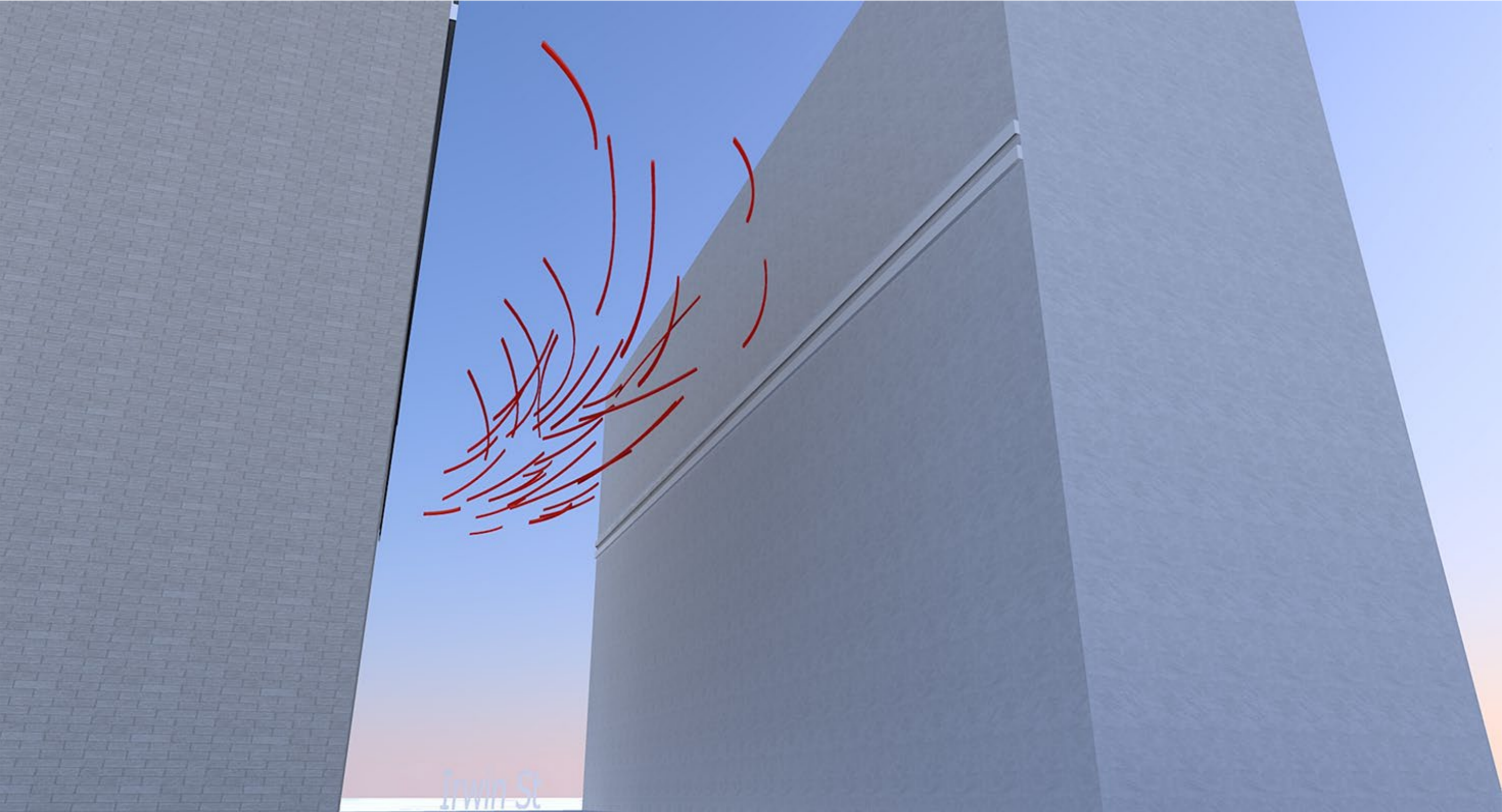

Indicative view of proposed artwork looking up from laneway.

# ARTWORK CONCEPT

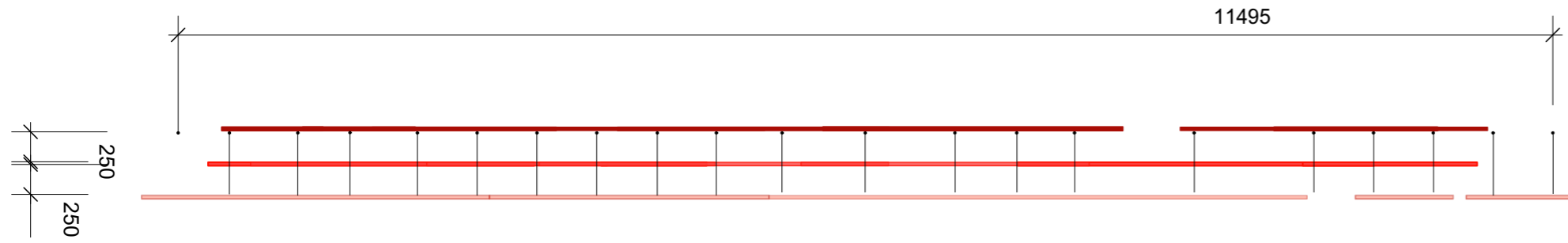

SIDE VIEW scale 1:50  
Indicating LED layers

LEGEND -	
<span style="display: inline-block; width: 20px; height: 10px; background-color: #800000; margin-right: 5px;"></span>	LEVEL A -
<span style="display: inline-block; width: 20px; height: 10px; background-color: #FF0000; margin-right: 5px;"></span>	LEVEL B -
<span style="display: inline-block; width: 20px; height: 10px; background-color: #FFA07A; margin-right: 5px;"></span>	LEVEL C -

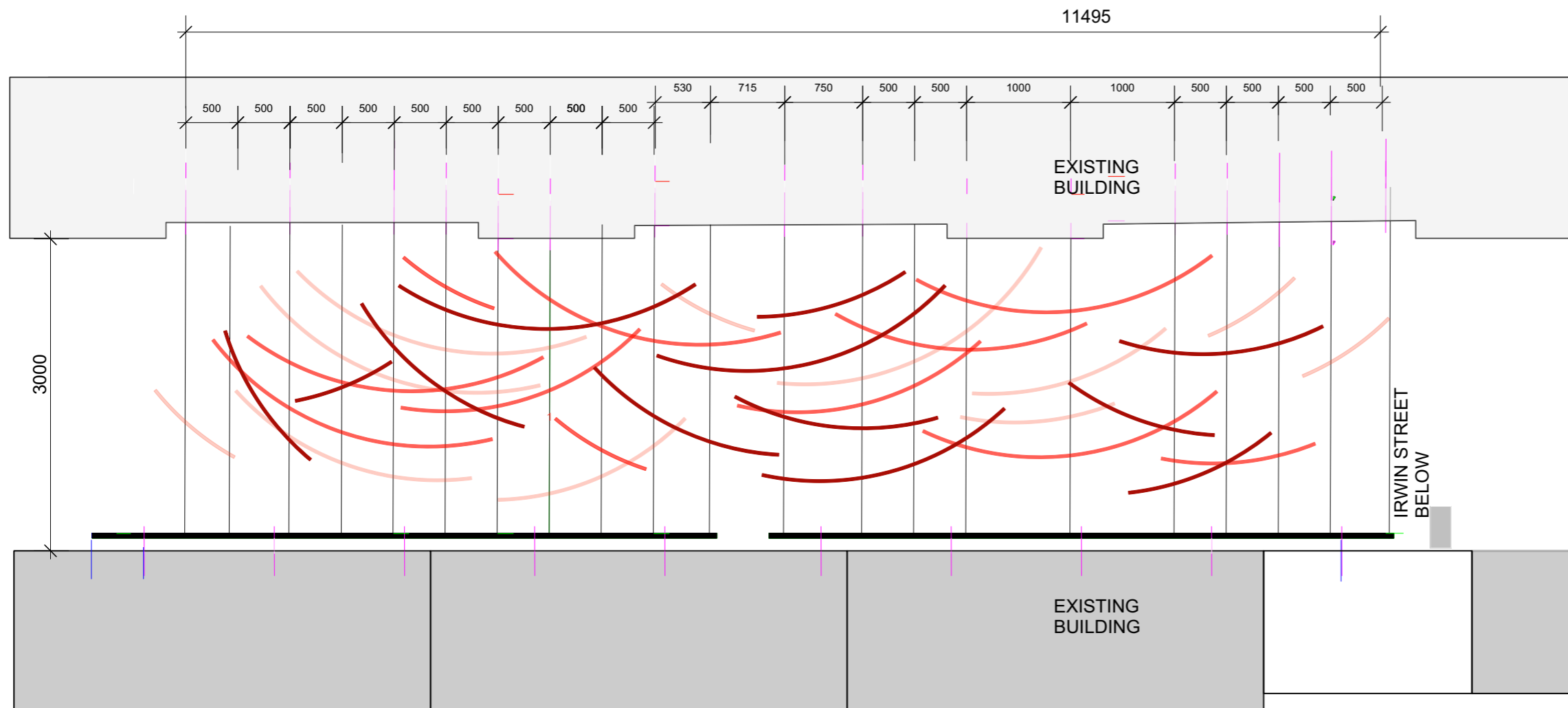

TOP PLAN scale 1:50  
Indicating LED layers and structure

View of LEDs showing different levels with colour coding. Custom suspension wire and rail system as per Light Application and engineer's specifications. The hanging system will allow the LEDs to be slightly suspended from the catenary wires at different heights (see drawing) to allow a controlled, gentle sway. This will add a physical aspect to the visual rhythm of the work.

Aerial perspective showing different levels with colour coding. The artwork will comprise x 70.5mts of custom cut LED lengths, measuring between 1mt to 3mts (as per drawing).

# ARTWORK CONCEPT

## Breakdown of LED lengths:

- 1m length x 7
- 1.5m length x 6
- 2m length x 6
- 2.5m length x 5
- 3m length x 10

Total 34 pieces = 73 metres

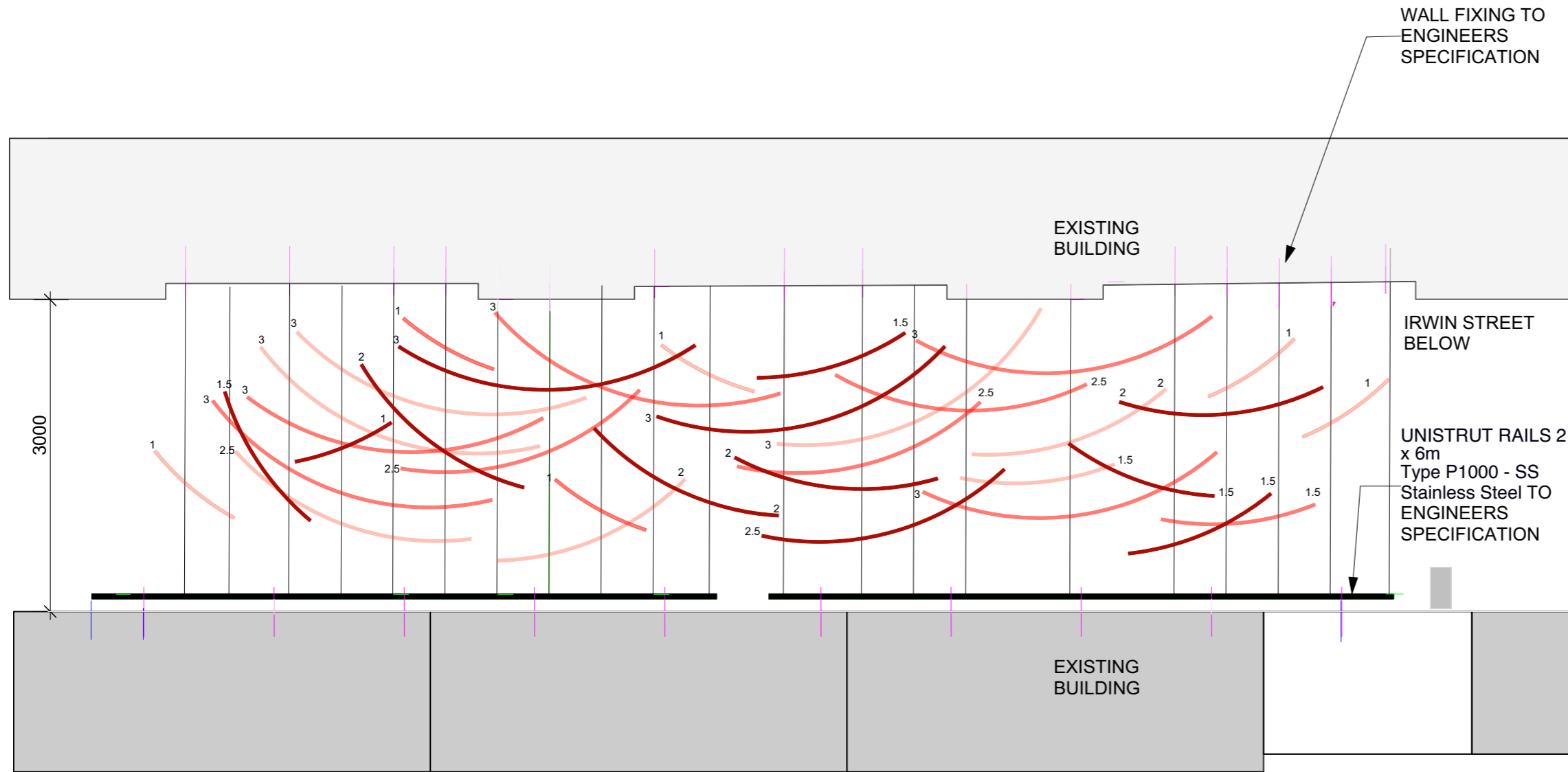

## LEGEND -

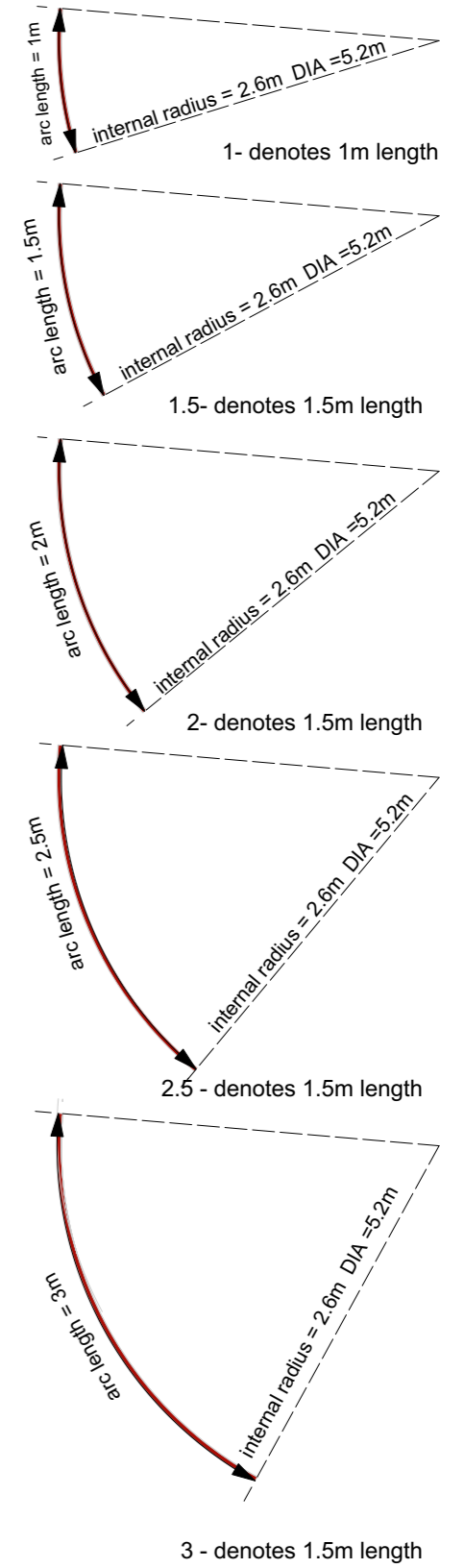

TOP PLAN scale 1:50  
Indicating LED configurations  
ALL LEVELS SHOWN.



# TOP LAYER\_LEVEL A

Breakdown of LED lengths:  
LEVEL A

- 1m length x 1
- 1.5m length x 4
- 2m length x 4
- 2.5m length x 1
- 3m length x 2

Total 11 pieces = 23.5 metres

The following pages show an aerial perspective of the three layers.

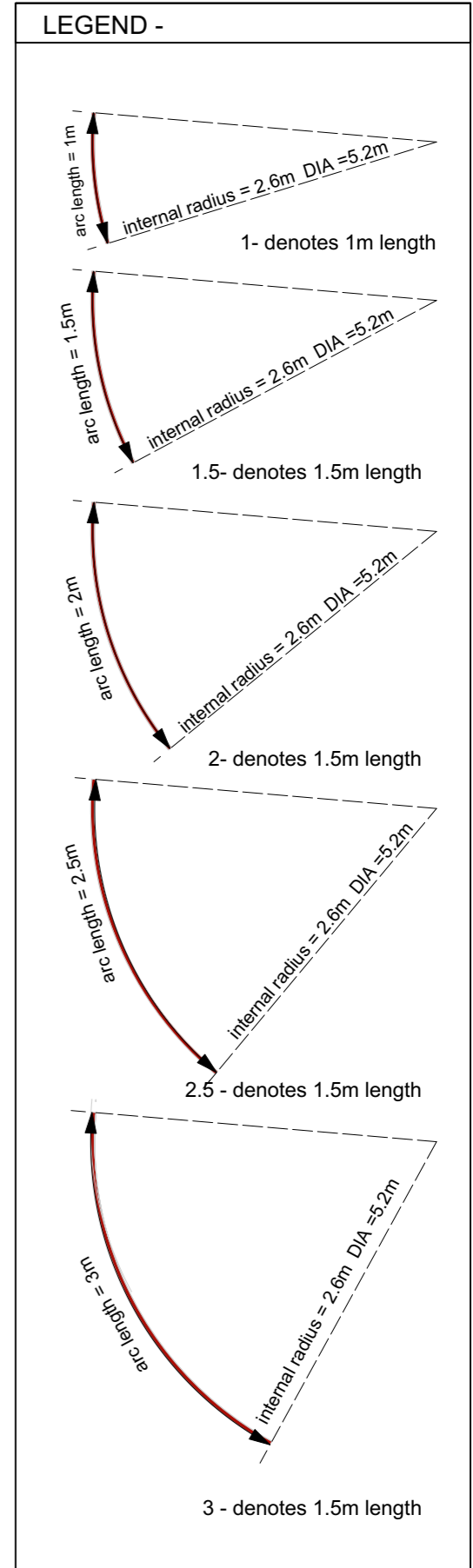
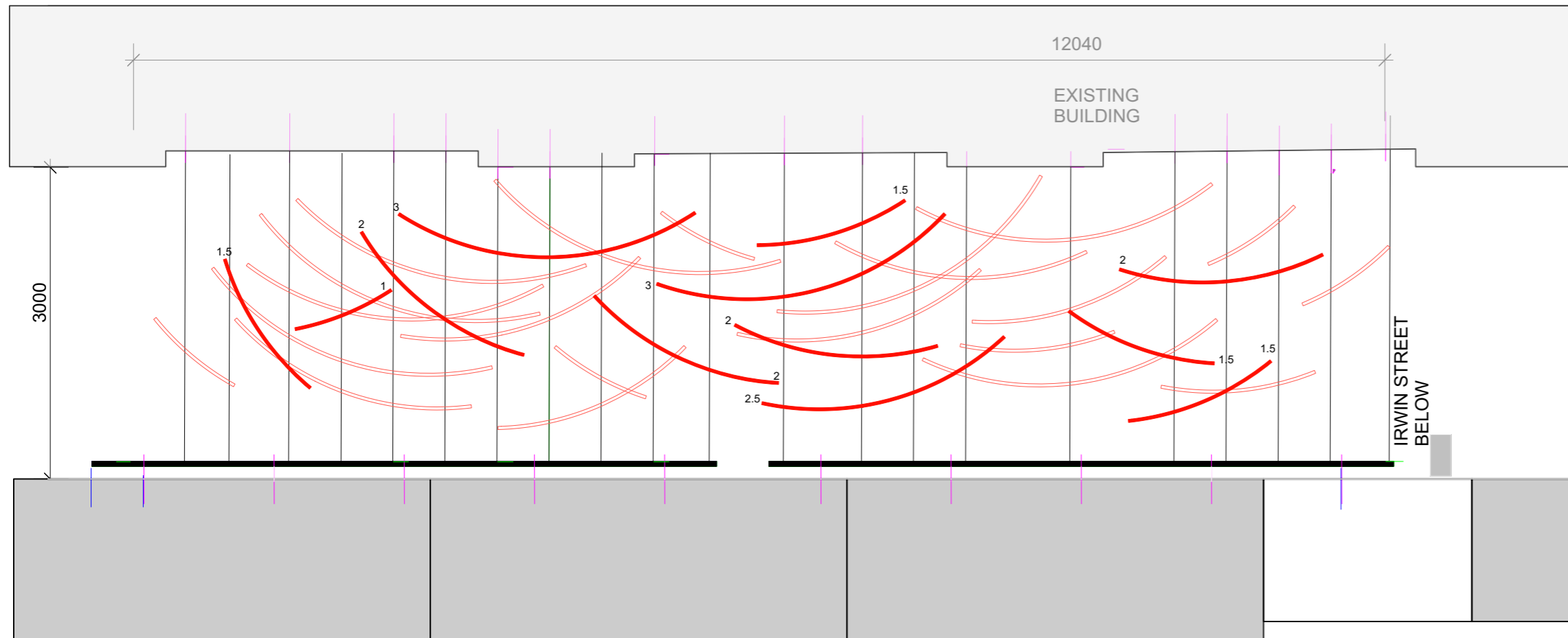

TOP PLAN scale 1:50  
Indicating LED configurations- LEVEL A  
( TOP LAYER )

# MIDDLE LAYER \_ LEVEL B

Breakdown of LED lengths:  
LEVEL B

- 1m length x 2
- 1.5m length x 1
- 2m length x 0
- 2.5m length x 3
- 3m length x 5

Total 11 pieces = 26 metres

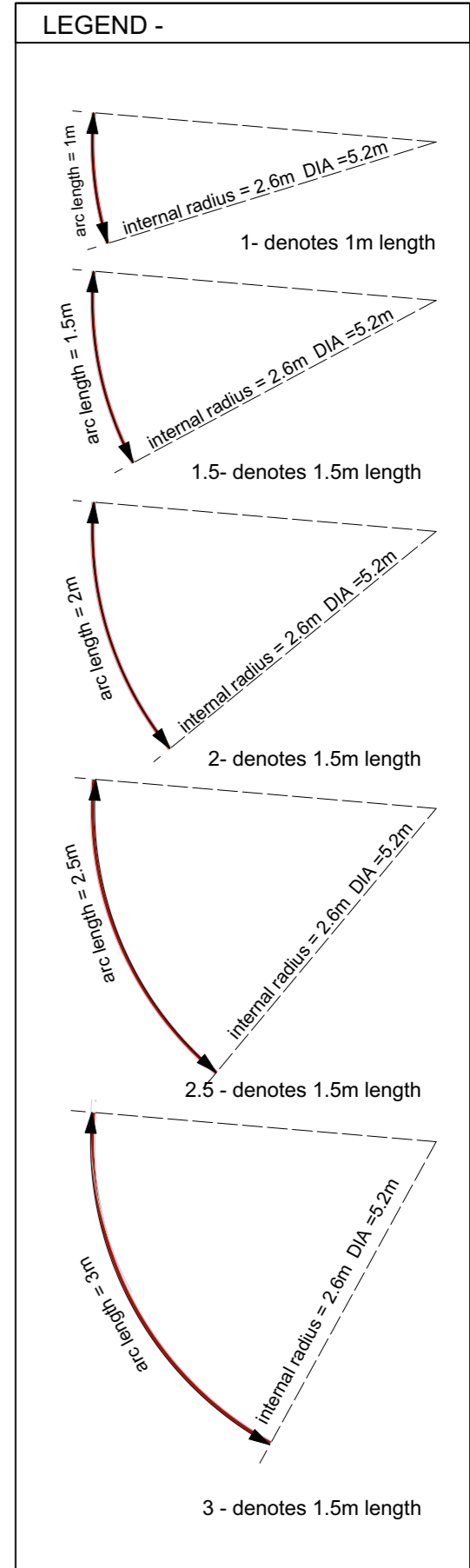
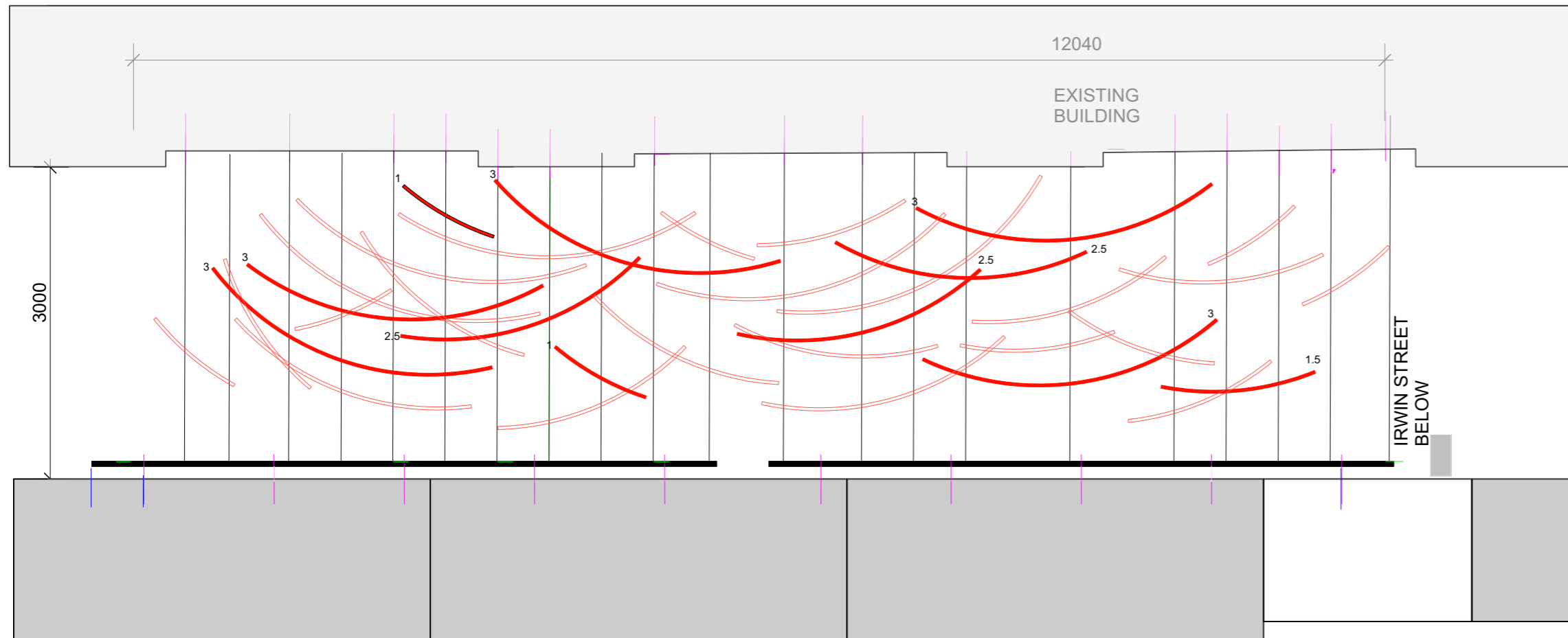

PLAN scale 1:50  
Indicating LED configurations- LEVEL B  
( MIDDLE LAYER )

# BOTTOM LAYER \_ LEVEL C

Breakdown of LED lengths:  
LEVEL C

- 1m length x 4
- 1.5m length x 1
- 2m length x 2
- 2.5m length x 1
- 3m length x 3

Total 11 pieces = 21.5 metres

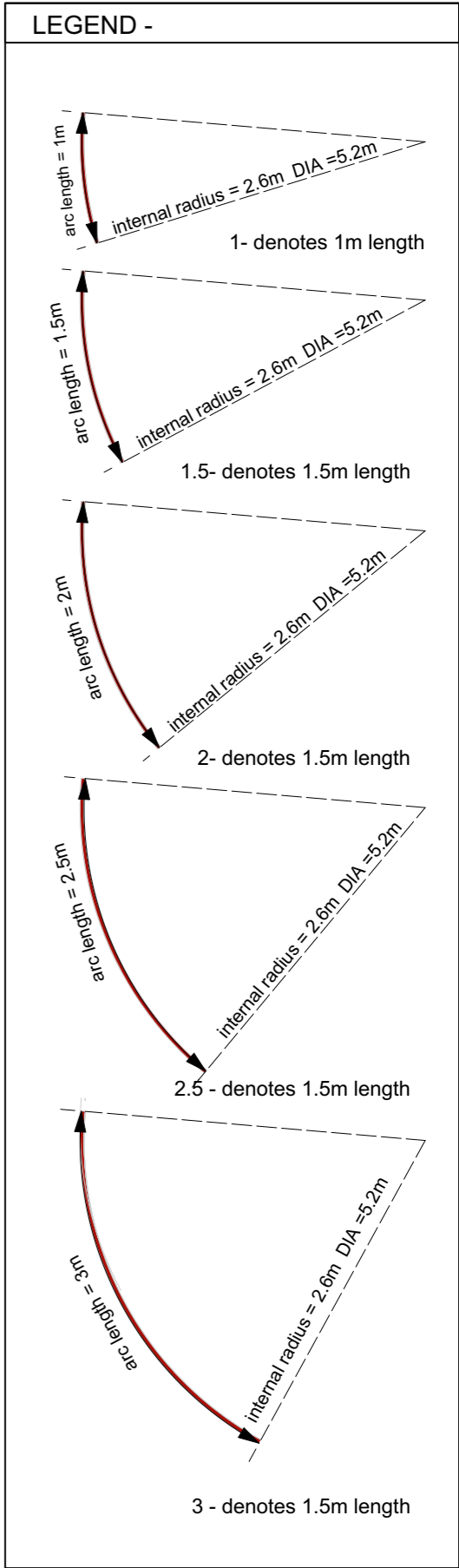
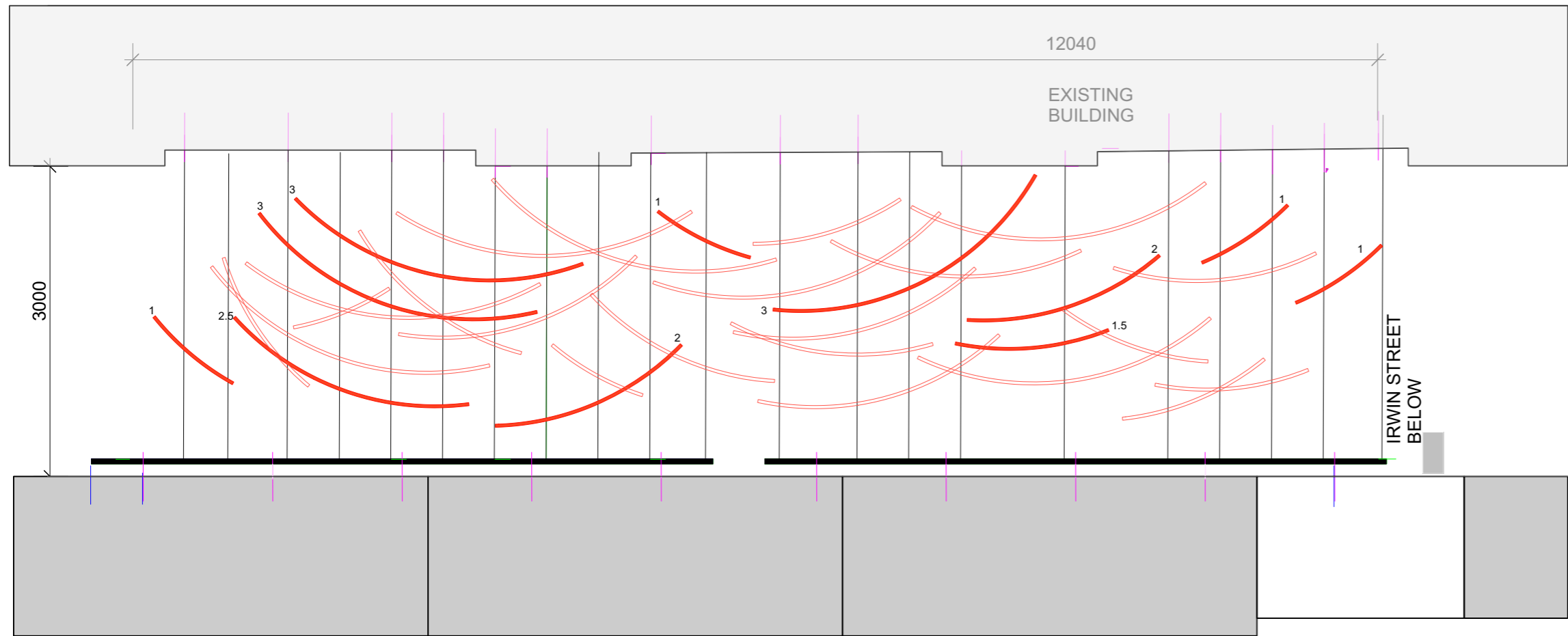

PLAN scale 1:50  
Indicating LED configurations- LEVEL C  
(BOTTOM LAYER)



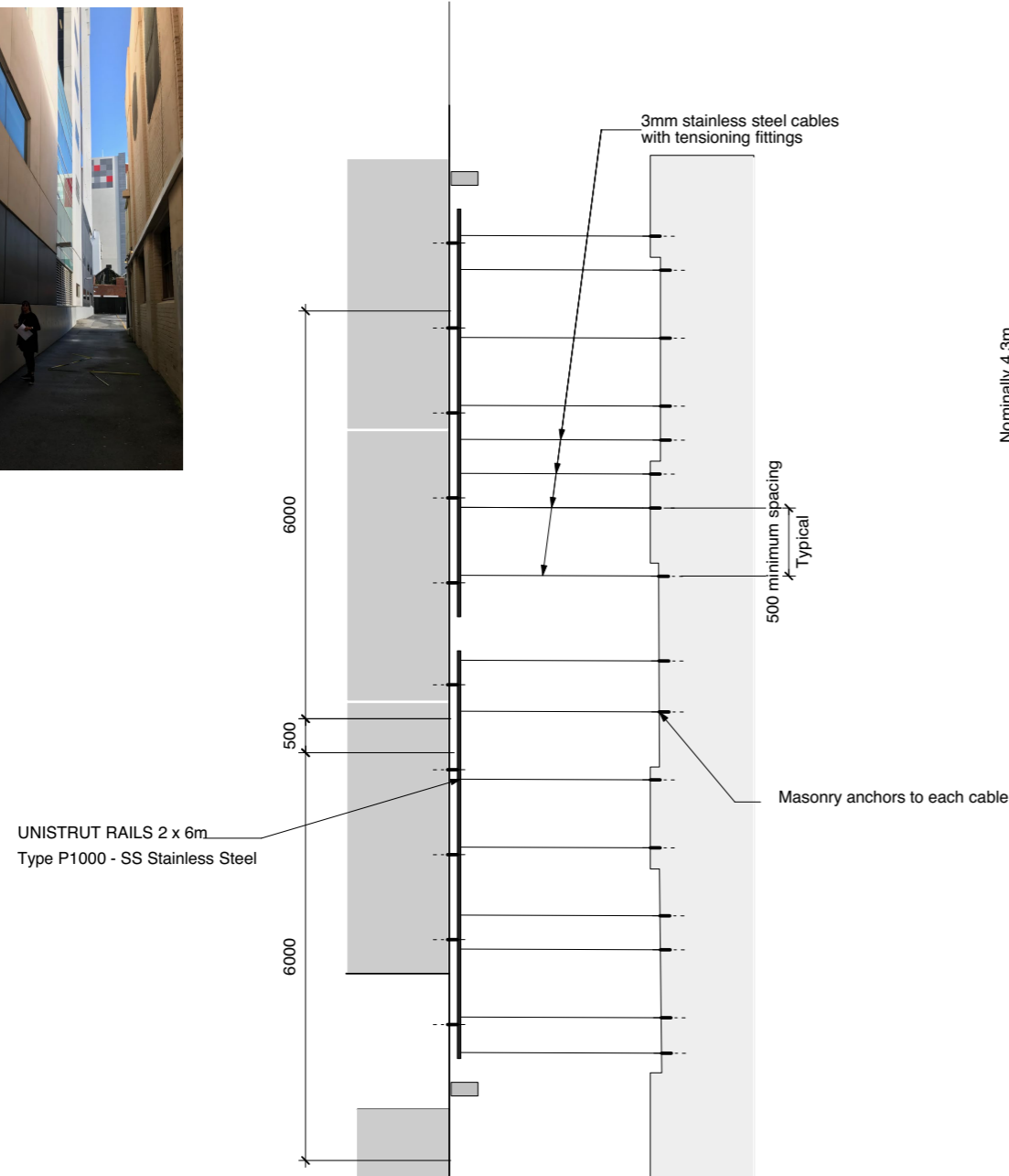
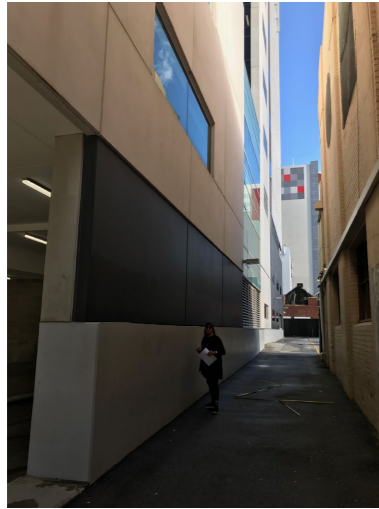

IRWIN STREET  
LAYOUT PLAN

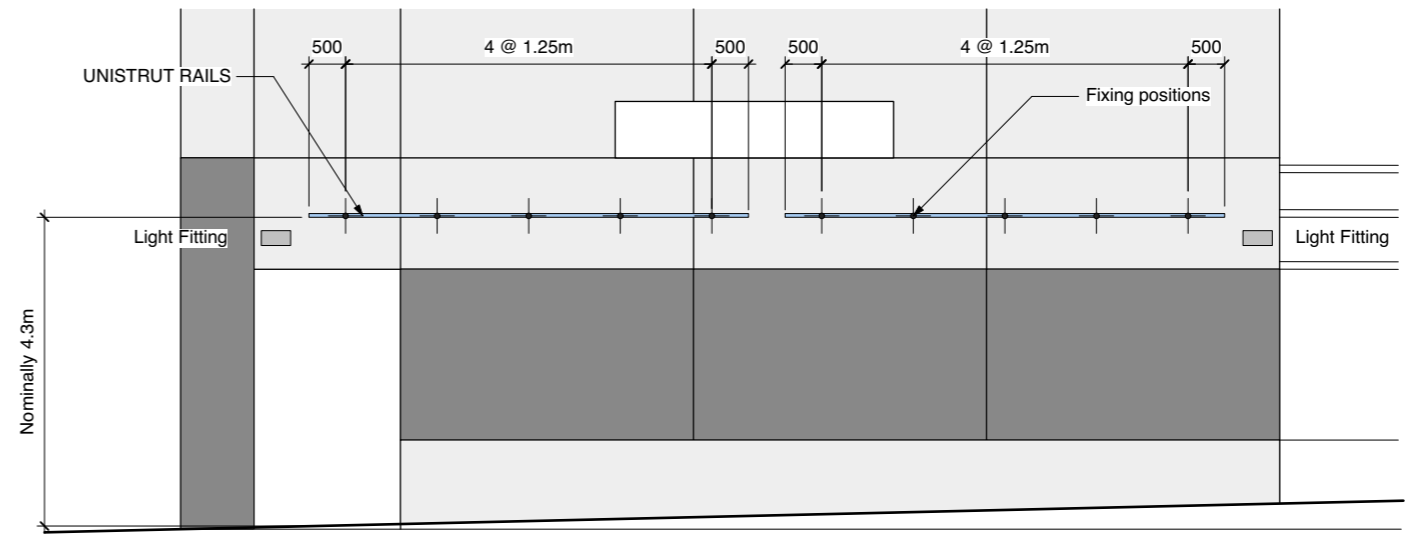

SOUTHERN ELEVATION

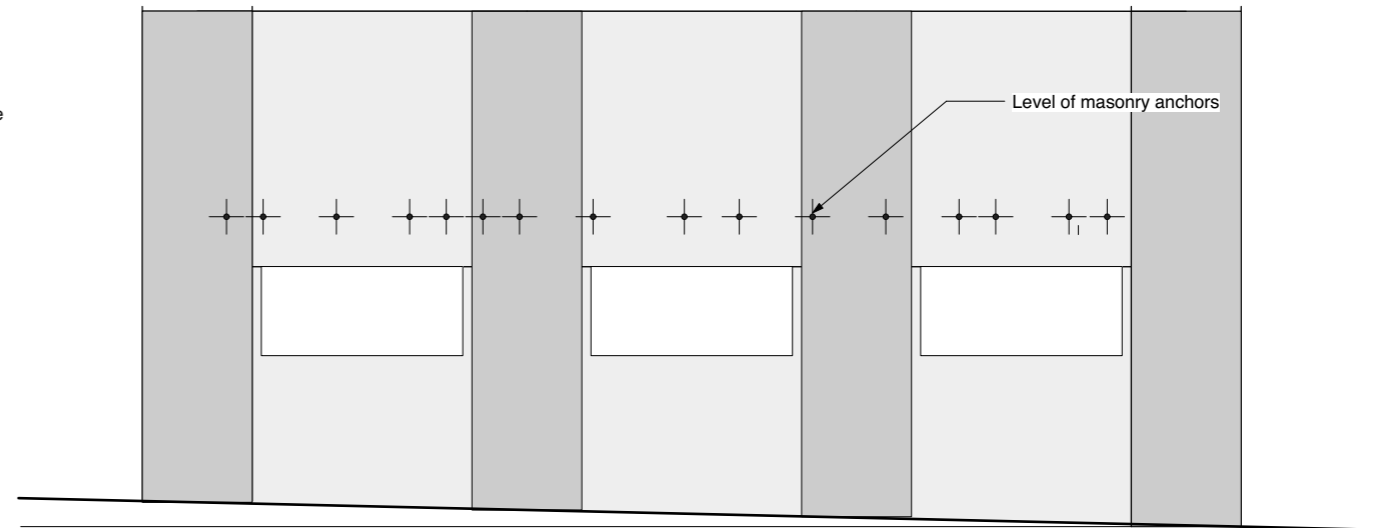

NORTHERN ELEVATION

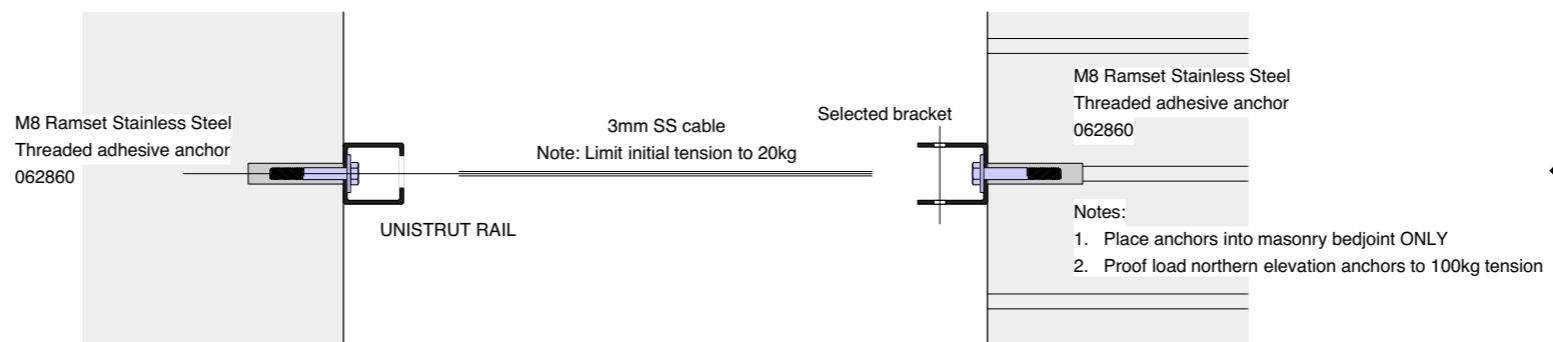

ATTACHMENT DETAILS

PRELIMINARY

Date	No.	Revision	By
24.08.21	0	ISSUE FOR APPROVAL & CONSTRUCTION	DM

Approved:			
Designed: <b>BN</b>	Drawn: <b>DM</b>	Checked:	Scale: <b>1: 100 (A3)</b>
Job No: <b>21098</b>	Drawing No: <b>S-01</b>	Revision:	<b>0</b>

# TECHNICAL

Please refer to engineers drawing for catenary structure details.

Please note: the minimum distance between catenary wires will be 500mm as per engineers specifications.

The proposed artwork uses coloured Flextube Arching LEDs (see attached specifications). This product has been recommended by Light Application for its superior external application for this project.

The LEDs are non-point source, thus offer a desirable diffused light perfect for this proposal. They are high efficacy, with low energy draw, totalling 868 watts and as such, contribute to sustainability.

Each led strip section is mounted within its own custom aluminium profile channel, rolled to form curved horizontal section (5200mm radius curve), and suspended from catenary by custom suspension cables (3mm stainless steel cable). Refer to details in Light Application drawing.

Weight estimate for LEDs approx 2.9kg per catenary cable, totalling 58.8kgs

PHAROS controller and 24v power supplies housed in IP67 rated wall mount enclosure at a location yet to be determined (City of Perth to advise). LEDs will be programmed to turn on and off at times negotiated with the City.

Also note: all Flextube LEDs will be customised made and IP68 rated with factory moulded cabling to prevent water egress, thus reducing maintenance. Flextube's guarantee is for two years. Light Application will guarantee their work for 12 months.

Currently the Irwin Street lane provides a functional pathway to the Curtin University buildings and carpark at the rear. The artist will liaise with the building owners to negotiate closure of the ROW during installation.

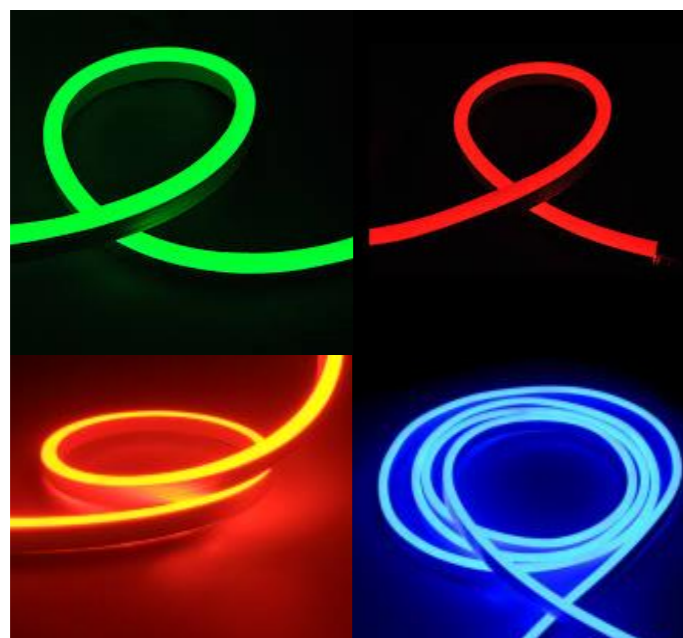

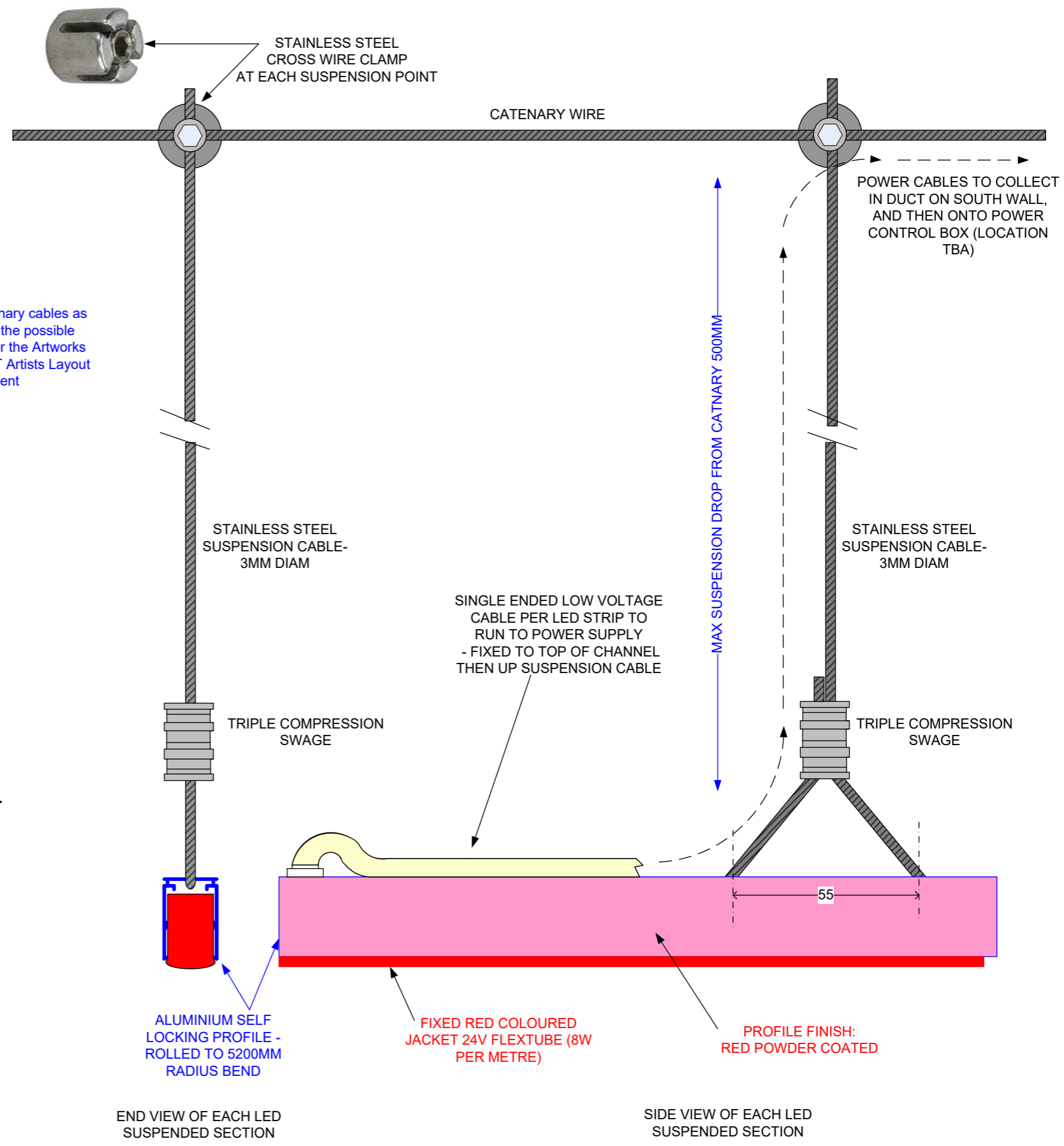
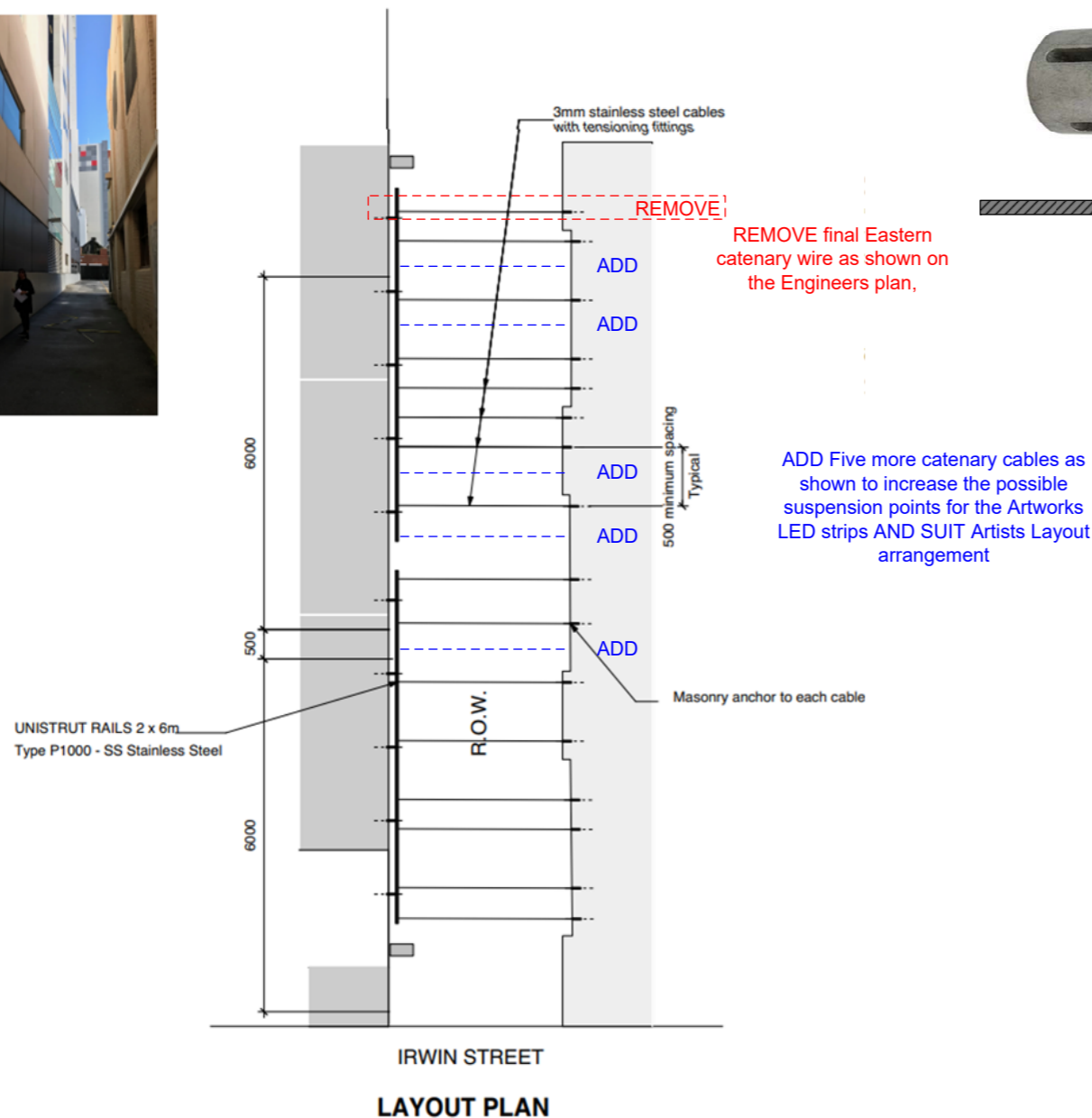
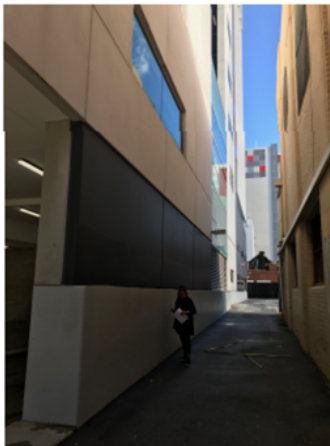

**SEE ENGINEERS DETAIL FOR CATENARY SUPPORT WIRES GENERAL ARRANGEMENT AND LAYOUT**

- EACH LED STRIP SECTION IS MOUNTED WITHIN ITS OWN CUSTOM ALUMINIUM PROFILE CHANNEL, ROLLED TO FORM CURVED HORIZONTAL SECTION (5200MM RADIUS CURVE), AND SUSPENDED FROM CATENARY BY CUSTOM SUSPENSION CABLES (3mm STAINLESS STEEL CABLE).
- TOTAL WEIGHT OF EACH LED SECTION:  

1m Section = 800gms	2 suspensions = 400gms per suspension point
1.5m Section = 1200gms	3 suspensions = 400gms per suspension point
2.0m Section = 1600gms	4 suspensions = 400gms per suspension point
2.5m Section = 2000gms	5 suspensions = 400gms per suspension point
3.0m Section = 2400gms	6 suspensions = 400gms per suspension point
- WEIGHT OF ARTWORK DISTRIBUTED OVER 20 CATENARY CABLES  
**APPROX 2.9KG PER CATENARY CABLE**  
**TOTAL ARTWORK: 58.8KGS**  
 TOTAL OF 73 LED STRIPS OF VARIOUS LENGTHS - see Artists Layout arrangement plan
- LIGHTWEIGHT CURVED LED SECTIONS SUSPENDED AT THREE LAYERS FROM CATENARY LEVEL:  
 0MM DROP, 250MM DROP, 500MM DROP.

END VIEW OF EACH LED SUSPENDED SECTION

SIDE VIEW OF EACH LED SUSPENDED SECTION



5/8 HASLER RD OSBORNE PARK 6017  
 WESTERN AUSTRALIA  
 Ph: 08 92406644  
 sales@lightapplication.com.au

TITLE: **LIGHT-IT-UP ARTWORK INSTALLATION  
 IRWIN STREET ROW  
 PAM GAUNT**

DRAWN DATE: 22 SEPT 2021  
 CLIENT: PAM GAUNT

SCALE: NTS  
 DRAWN:  
 CHECKED:  
 APPROVED:

REV: 2  
 SIZE: A2



# BUDGET & ACKNOWLEDGMENTS

## Budget

(NB: All prices are ex gst)

Light Application Fee (includes: supply custom made LEDs & related electrical equipment; catenary wire and rail system; installation; equipment hire; Pharos Controller; cables & connectors etc.) \$28,830

Engineers Fee: \$2,000

Powder coating: \$300

Contingency: \$670

Artist Fee: \$7,300

**Total: \$39,500 ex gst**

## Acknowledgements

Caroline Di Costa, cdc creates  
Brian Nelson, Director, Capital House Australasia  
David Sparrow, Light Application, specialists in lighting and lighting control.  
City of Perth



# Flextube – Flat

PL-Flextube-COLOUR-F/24V

The **pureLED FlexTube** range includes a wide selection of neon-like LED strip.

Manufactured from UV resistant PVC and IP68 rated from factory, the **FlexTube** range has been designed for both indoor and outdoor environments and can be utilised in a wide range of applications including signage, cove lighting, feature lighting, decorative trim and more. It is available in a range of single colour variants, tuneable white and full colour RGB and RGBW to meet the needs of any installation where a dimmable continuous and diffused light is required.

**FlexTube** is available in a range of profiles including flat face, domed face, side emitting and front emitting. Coloured diffusers are also available to maintain colour visibility when not illuminated.

A range of stylish aluminium extrusions, trim pieces, joiners and crossover joints are available to ensure a high aesthetic standard is maintained where **FlexTube** is directly viewable.

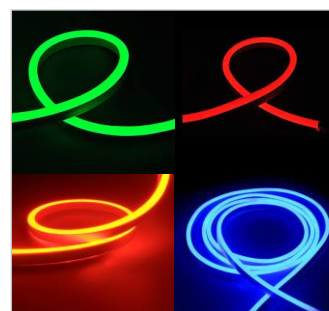

**Colour options:**  
RGBW (2700K), CCT RGBW (4000K),  
RGB, R, G, B, A, 2700, 3000, 3500, 4000,  
4500, 5700

<b>Part #</b>	PL-FlexTube-COLOUR-F/24V
<b>Lamp Type:</b>	LED
<b>Colour Temp:</b>	2000K-6500K, Tunable White, Red, Green, Blue, Amber, RGB, RGBW
<b>Lumen Output:</b> (per/m)	White 3000-4500K 320lm, Red 100lm, Green 360lm, Blue 35lm, Amber 75lm,
<b>CRI:</b>	80
<b>Power:</b> (At Maximum Output)	White 12W/m, Red & Amber 7.2W/m, Green & Blue 12W/m, RGB 12W/m, RGBW 15W/m
<b>Lumen Maintenance:</b>	L70 @ 50000hrs
<b>Beam Angle:</b>	160°
<b>IP Rating:</b>	IP68 – Moulded Ends / IP67 – Clip-on Connectors Driver IP20, IP65 Available on Request
<b>Dimming Options:</b>	DALI, DMX, sACN, SPI, ArtNet.



# Flextube - Flat

PL-Flextube-COLOUR-F/24V

## Dimensions

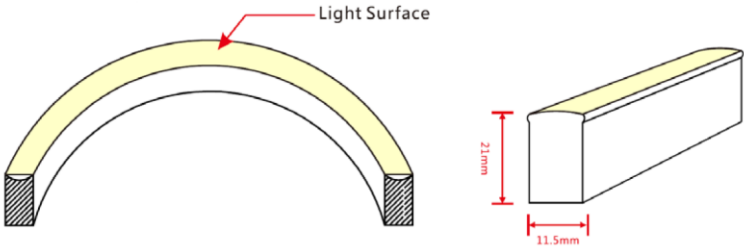

## Mounting Accessories

### Aluminium Standard Profile

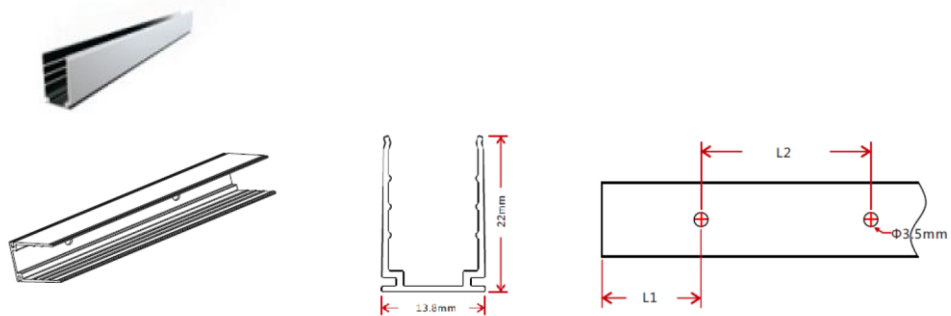

W*H(mm)	Standard Length ( L:mm)	L1 (mm)	L2 (mm)	Screw Hole (Φ:mm)	Hole Number
13.8*22	30	15	/	Φ3.5	1
	50	25	/	Φ3.5	1
	500	50	200	Φ3.5	3
	1000	100	200	Φ3.5	5
	2000	100	200	Φ3.5	10

### Aluminium Flange Profile

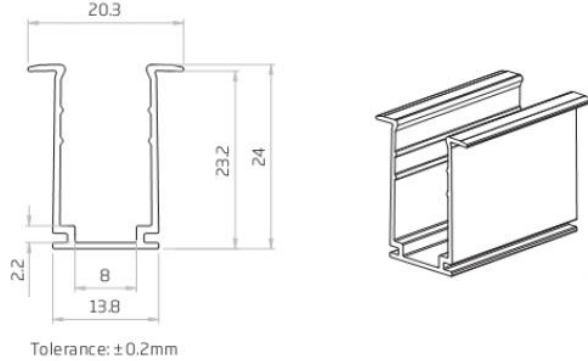



### Mounting Accessories

#### Aluminium Serrated Profile

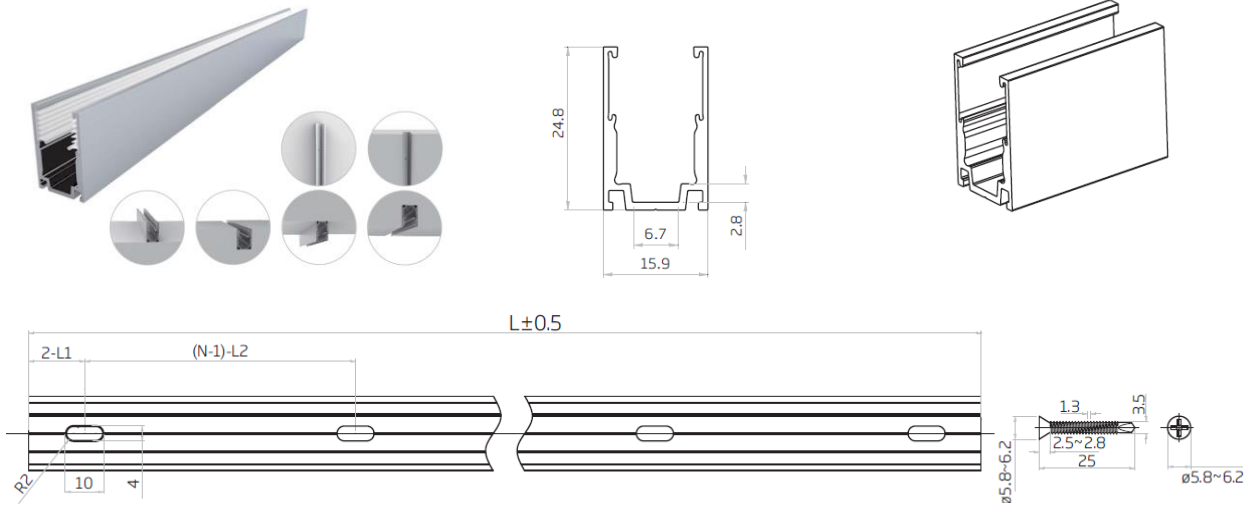

Standard Length	L1	L2	Screw Hole	Hole Number
20mm/0.787in	10mm/0.39in	/	4*10mm/0.16*0.39in	1
500mm/19.68in	50mm/1.97in	200mm/7.87in	4*10mm/0.16*0.39in	3
1000mm/39.37in	100mm/3.93in	200mm/7.87in	4*10mm/0.16*0.39in	5
2000mm/78.74in	100mm/3.93in	200mm/7.87in	4*10mm/0.16*0.39in	10

#### Aluminium Self-Locking Profile

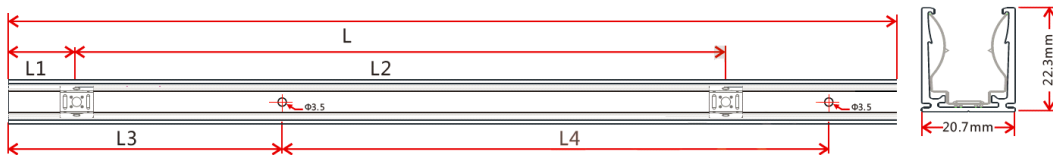
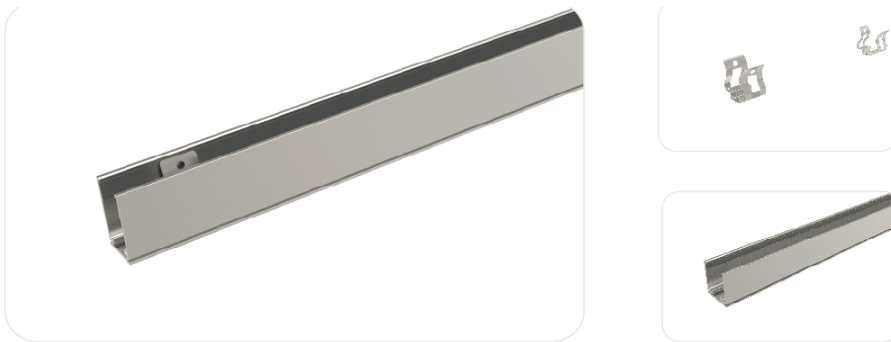

W*H(mm)	Standard Length(mm)	L1(mm)	L2(mm)	L3(mm)	L4(mm)	Hole Screw(mm)	Hole Number	Clip Number
20.7*22.3	35	17.5	/	5	25	Φ3.5	2	1
	500	25	150	50	200	Φ3.5	3	4
	1000	25	190	100	200	Φ3.5	5	6
	2000	25	195	100	200	Φ3.5	10	11

## Mounting Accessories

Plastic/Aluminium Profile

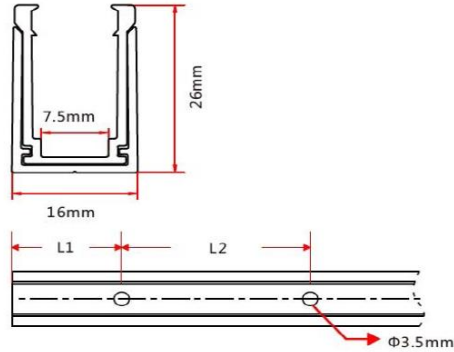

W*H(mm)	Standard Length (mm)	L1 (mm)	L2 (mm)	Screw Hole (mm)	Hole Number
16*26	35	17.5	/	Φ3.5	1
	500	50	200	Φ3.5	3
	1000	100	200	Φ3.5	5
	2000	100	200	Φ3.5	10

## Plastic Profile

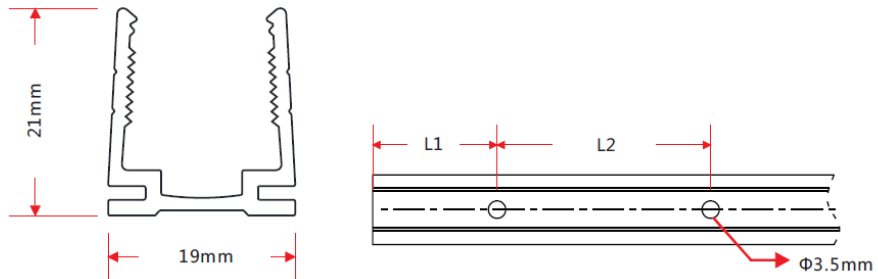
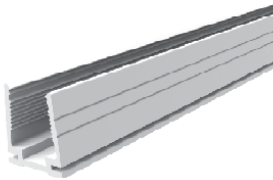

W*H(mm)	Standard Length (L:mm)	L1 (mm)	L2 (mm)	Screw Hole (Φ:mm)	Hole Number
19*21	300	50	200	Φ3.5	2
	500	50	200	Φ3.5	3
	1000	100	200	Φ3.5	5
	2000	100	200	Φ3.5	10



Mounting Accessories

Aluminium Flange Serrated Profile

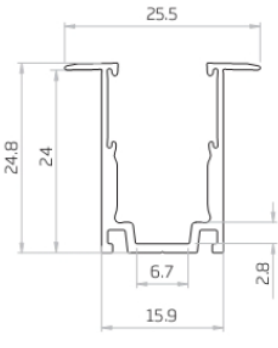

Tolerance: ±0.2mm

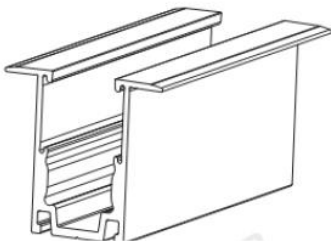

Aluminium Bendable Serrated Profile

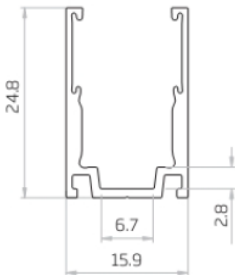
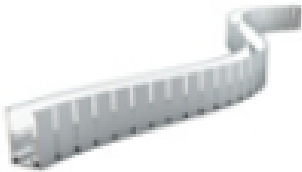

Tolerance: ±0.2mm

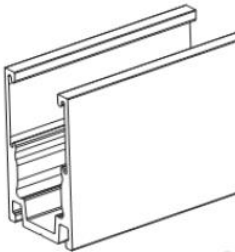

Bendable 316 Stainless Steel Profile

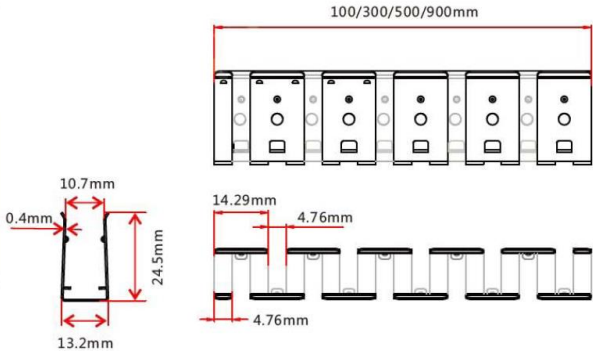



# Flextube - Flat

PL-Flextube-COLOUR-F/24V

## Connectors

Injection Moulded End Entry—IP67, Factory Fitted Only

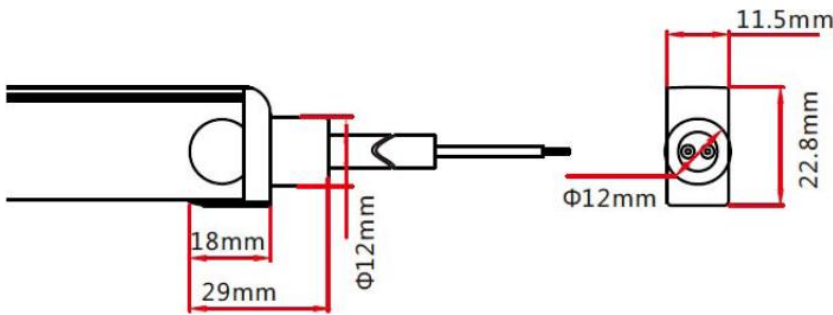
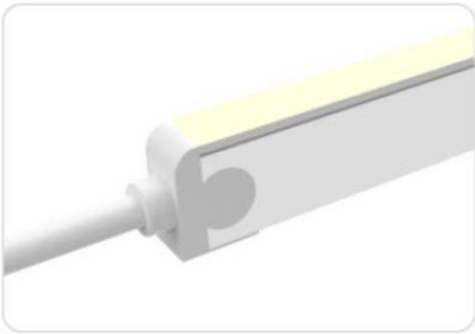

Injection Moulded Side Entry—IP67, Factory Fitted Only

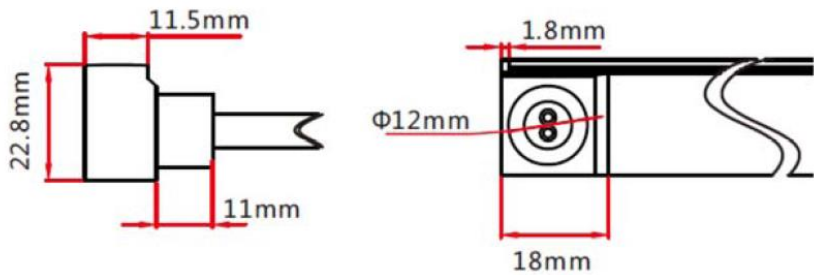
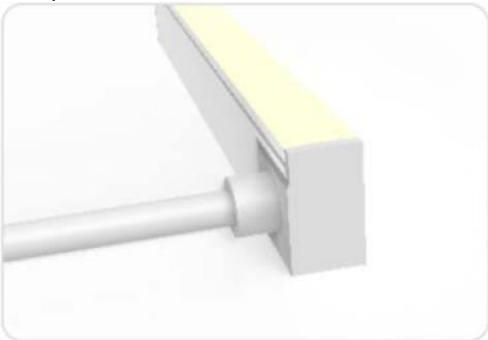

Injection Moulded Rear Entry—IP67, Factory Fitted Only

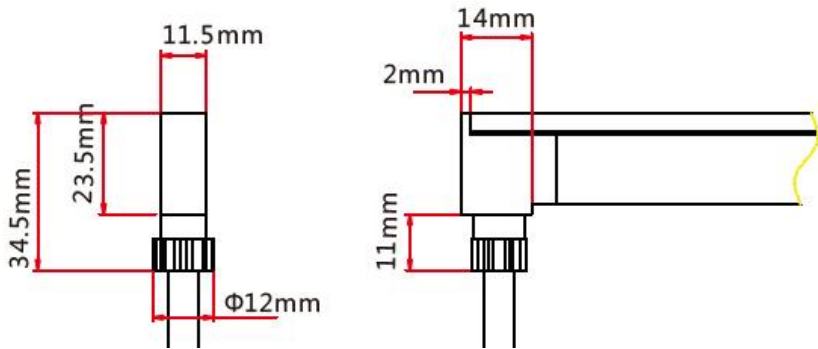

Clamp Type—IP67, Factory or Onsite Fitted

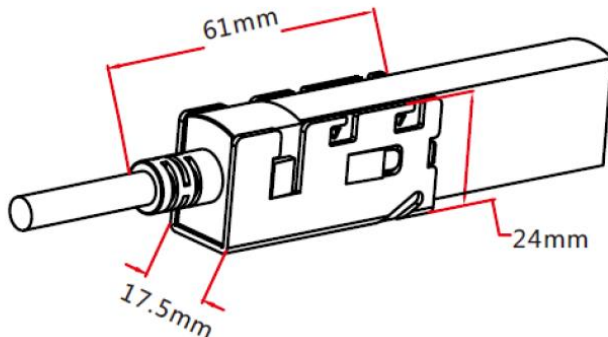
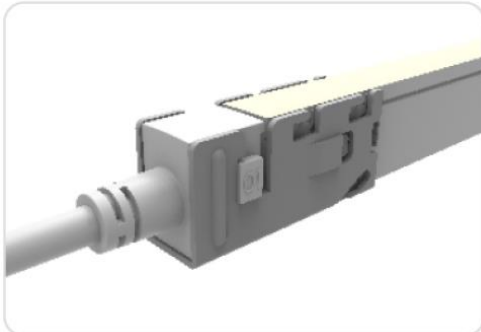





# Flextube - Flat

PL-Flextube-COLOUR-F/24V

Snap Type—IP67, Factory or Onsite Fitted

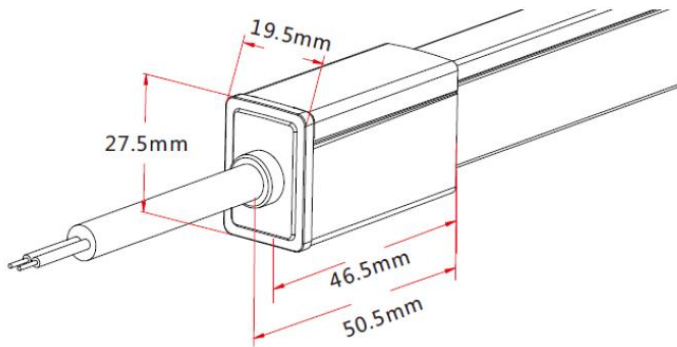
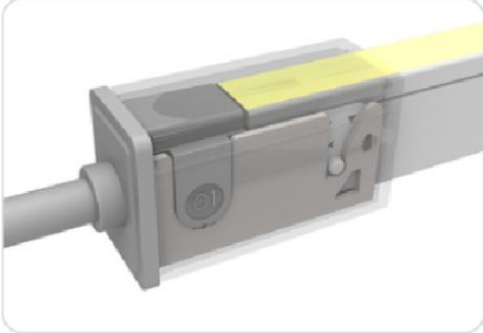

Double Injection Moulded End Entry—IP68, Factory Fitted Only

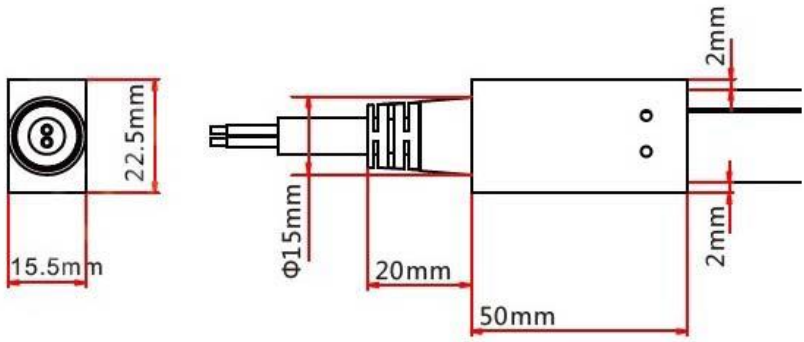

Double Injection Moulded Side Entry—IP68, Factory Fitted Only

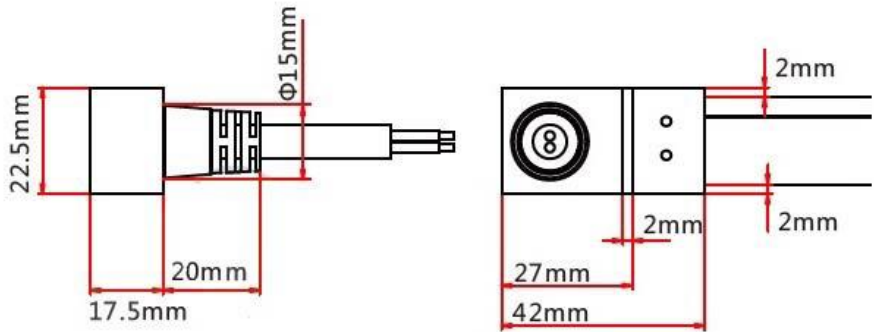
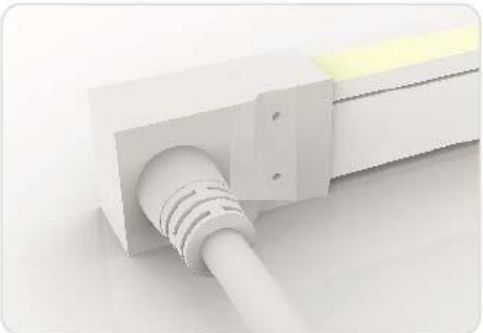

Double Injection Moulded Rear Entry—IP68, Factory Fitted Only

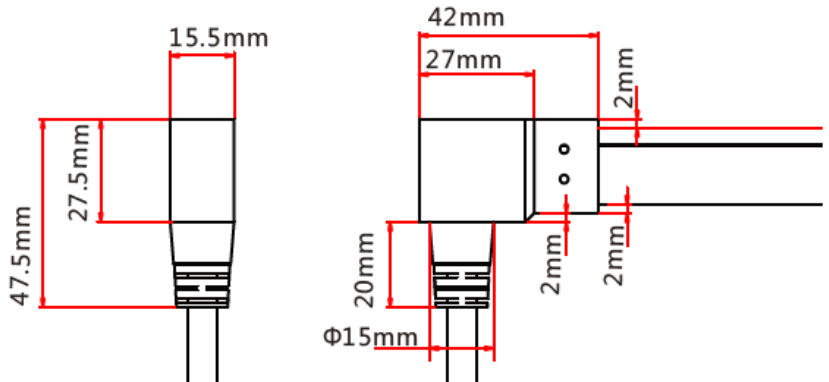

Snap Side Entry Type—IP67, Factory or Onsite Fitted

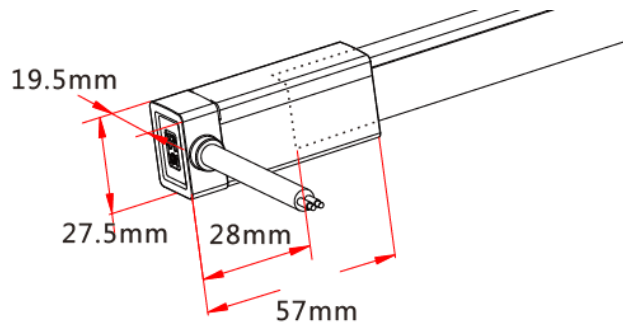

Snap Rear Entry Type—IP67, Factory or Onsite Fitted

